

# BORE GAGES FOR BLIND HOLES

**INSIZE** PLUS  
MADE IN EUROPE

POINT HEIGHT  $H > 0.5\text{mm}$   
CAN BE CUSTOMIZED

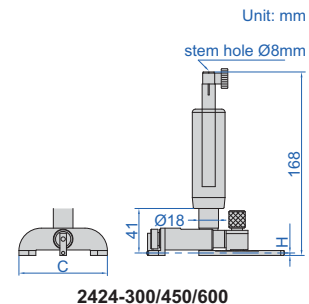
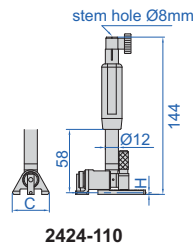
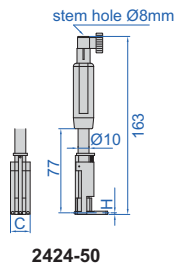

- To measure diameter of shallow and blind holes
- Optional accessory:
  - 0.01mm or 0.001mm graduation dial indicators
  - Setting ring (code **6312**)
  - Long handle (code **7352**)
  - Bore gage setter



Code	Range	Accuracy (without dial indicator)	Repeatability (without dial indicator)	C	H
<b>2424-50</b>	20-50mm	4 $\mu\text{m}$	1 $\mu\text{m}$	18mm	1.5mm
<b>2424-110</b>	50-110mm	4 $\mu\text{m}$	1 $\mu\text{m}$	34mm	1.5mm
<b>2424-300</b>	110-300mm	4 $\mu\text{m}$	1 $\mu\text{m}$	81mm	2.2mm
<b>2424-450</b>	200-450mm	4 $\mu\text{m}$	1 $\mu\text{m}$	81mm	2.2mm
<b>2424-600</b>	300-600mm	4 $\mu\text{m}$	1 $\mu\text{m}$	140mm	2.2mm